



## SERVICE DOCUMENTATIE

voor de ontvanger

### 2029 A

1956. Voor voeding uit wisselstroomnetten 50 ~

#### GOLFBEREIKEN

F.M. : 87,5 - 100 MHz  
 M.G. : 185 - 580 m (1620 - 517 kHz)  
 L.G. : 1150 - 2000 m (260 - 150 kHz)

#### BEDIENINGSKNOPPEN

Van links naar rechts:

Grote knop : Toonregelaar  
 Kleine knop: Volume regelaar

Grote knop }  
 Kleine knop } Afstemming

Druktoetsen

Netschakelaar  
 P.U. schakelaar  
 Toets M.G.  
 Toets L.G.  
 Toets F.M.

#### BUIZEN

B1 : ECH81  
 B2 : EF 89  
 B3 : EF 85  
 B4 : EABC80  
 B5 : EL 84  
 B6 : EZ 80  
 B7 : ECC85

#### MIDDENFREQUENTIES

F.M. : 10,7 MHz  
 A.M. : 452 kHz

#### NETSPANNINGEN

110-127-145-220 V

#### VERBRUIK

55 Watt.

#### AFMETINGEN

48 x 10, x 210 mm

#### SCHAALLAMPJE

8024 N -91

#### LUIDSPREKER

AD 3700 M

(Z = 5 Ω)

93 986 10.1.22

HET AFREGELLEN VAN DE ONTVANGERI. A.M. GEDEELTE

Volumeregelaar op maximum. Toonregelaar op kwaliteit. Een voltmeter via trimtransformator aansluiten op de bussen voor de extra luidspreker.

Indien niet anders is aangegeven worden alle signalen via een kunst-antenne aan de antennebus toegevoerd.

De wijzer bij minimum stand van de afstemcondensator instellen op trimpunt 1.

M.F. BANDFILTERS

De kernen der M.F. bandfilters uitdraaien.

Bereik	Signaal	Wijzer op trimpunt	Afregelen	Aanwijzing Voltmeter
M.G.	452 kHz via 33000 pF aan g1B1	1	S19, S18 S14, S15	max. max.

M.F. SPER- EN ZUIGKRING

De kernen S8 en S9 uitdraaien.

M.G.	452 kHz	3	S8, S9, S8	<u>min.</u>
------	---------	---	------------	-------------

H.F. KRINGEN

M.G.	550 kHz 1500 kHz	3 2	S11, S5 C6, C5	max. }herhalen max. }
L.G.	259,5kHz 157 kHz	2 3	C15, C13 S6	max. }herhalen max. }

II. F.M. GEDEELTE

Volumeregelaar op maximum, toonregelaar op kwaliteit.  
 Een diodevoltmeter (D.V.) in serie met 0,1 MΩ aansluiten over R18.  
 Een voltmeter aansluiten op de bussen voor de extra luidspreker, via een trimtransformator.  
 Indien niet anders is aangegeven zijn alle signalen ongemoduleerd.

<u>M.F. KRINGEN</u>				
De kernen van S23, S17, S13, S28 uitdraaien.				
Signaal	Wijzer op trimpunt	Oscillator aansluiten op	Afregelen	Aanwijzing
10,7 MHz	3	g1B3 via 1500 pF	S20	Max. D.V. (- 3 V)
10,7 MHz A.M. ge- moduleerd (500 Hz)	3	g1B3 via 1500 pF	S22-23	<u>Min.output</u>
10,7 MHz	3	g1B2	S16, S17	Max. D.V. (± 8 V)
10,7 MHz	3	g1B1	S12, S13	Max. D.V. (± 8 V)
10,7 MHz	3	F.M. $\overline{\Gamma} \perp \underline{\underline{\text{G}}}$	S58, S28	Max. D.V. (± 8 V)
<u>H. F. KRINGEN</u>				
100 MHz	100 MHz	F.M. $\overline{\Gamma} \perp \underline{\underline{\text{G}}}$	S55 (1 <sup>e</sup> piek) S56-57 C86 (1 <sup>e</sup> piek) C89	Max. D.V. Max. D.V. Max. D.V.
87,5 MHz	87,5 MHz	F.M. $\overline{\Gamma} \perp \underline{\underline{\text{G}}}$	S55 (1 <sup>e</sup> piek) S56-57	Max. D.V. Max. D.V.

TRANSFORMATOREN

Indien de voedingstransformator defect raakt dient deze te worden vervangen door de service transformator die in de elektrische stuklijst vermeld is.

Zie hiervoor het bedradingsschema "boven". Punt 1 van de originele transformator komt overeen met punt 1 van de service transformator, enz.

MECHANISCHE STUKLIJST

Kast	A3 770 77.0
Grote knop (afstemming)	A3 752 49.0
Grote knop (toonregelaar)	A3 769 58.0
Kleine knop (volumeregelaar, afstemming)	A3 769 27.0
Variabele condensator F.M.	49 001 84.0
Trommel van variabele condensator (AA)	P4 380 53.0
Variabele condensator	49 001 96.0
Schaal (N)	A3 807 06.0
Schaal (Z)	A3 807 09.0
F.M. Unit	A9 998 01/00
Tule schaalbevestiging	P5 420 03.0
Spanningsomschakelaar	A3 228 81.0
	<i>hd</i>

WM/SR

S1			C1	50 $\mu$ F	A9 999 12/L50+
S2			C2	50 $\mu$ F	50
S3		A3 141 35.3	C3, C4	12-496 pF	49 001 96.0
Z1			C5	22 pF	49 005 59.4
S5-6		A3 117 83.0	C6	22 pF	49 005 59.4
S8-9			C7	1500 pF	A9 999 04/1K5
C9	5,6 pF	A3 119 70.0	C8	3000 pF	A9 999 05/3K
C10	240 pF		C11	100 pF	A9 999 04/100E
S10			C12	100 pF	A9 999 04/100E
S11		A3 125 99.0	C13	60 pF	A9 999 08/60E
S12			C14	270 pF	A9 999 05/270E
S13			C15	100 pF	A9 999 07/20-
C19	18 pF	A3 127 86.0	C16	10000 pF	100E
C20	33 pF		C17	68 pF	A9 999 04/10K
S14			C18	470 pF	A9 999 04/470E
S15			C24	4700 pF	A9 999 04/4K7
C22	110 pF	A3 126 84.0	C25	4700 pF	A9 999 04/4K7
C23	195 pF		C30	33 pF	A9 999 04/33E
S16			C31	6800 pF	A9 999 04/6K8
S17			C32	10000 pF	A9 999 04/10K
C26	33 pF	A3 127 00.0	C33	47 pF	A9 999 04/47E
C27	33 pF		C34	4700 pF	A9 999 04/4K7
S18			C37	6800 pF	A9 999 04/6K8
S18			C38	4700 pF	A9 999 04/4K7
C28	195 pF	A3 127 72.0	C39	1000 pF	A9 999 06/1K
C29	195 pF		C40	10 $\mu$ F	A9 999 09/E10
S20			C41	4700 pF	A9 999 04/4K7
S21			C42	8200 pF	A9 999 06/8K2
S22			C43	4700 pF	A9 999 04/4K7
S23		A3 127 01.0	C44	15000 pF	A9 999 06/15K
C35	47 pF		C45	0,27 $\mu$ F	A9 999 06/270K
C36	22 pF		C46	4700 pF	A9 999 06/4K7
S24			C47	2700 pF	A9 999 06/2K7
S25			C48	4700 pF	A9 999 06/4K7
S26		A3 152 92.0	C49	0,47 $\mu$ F	A9 999 06/470K
S27			C50	6,8 pF	A9 999 04/6E8
S28			C52	100 pF	A9 999 04/100E
C51	15 pF	A3 127 83.0	C53	4700 pF	A9 999 04/4K7
S40			C54	10000 pF	A9 999 04/10K
S41		WE 110 61.0	C80	6,8 pF	A9 999 04/6E8
S50			C81	1500 pF	A9 999 04/1K5
S51			C82	2,7 pF	A9 999 04/2E7
S52		A3 119 72.0	C83	33 pF	A9 999 04/33E
S53			C85	15 pF	A9 999 04/15E
S54			C86	6 pF	49 627 50.0
S55		A3 119 79.0	C88	12 pF	A9 999 04/12E
S58			C89	6 pF	49 627 50.0
S59		A3 127 82.0	C90	82 pF	A9 999 04/82E
			C91	933 pF	A9 999 05/910E
			C93	10000 pF	A9 999 04/10K
			C94	12 pF	A9 999 04/12E
			C95	2200 pF	B1 664 25.0
			C96	2200 pF	B1 664 25.0
			C97	2200 pF	B1 664 25.0

R1	900 Ω	2xB1 636 10.0	R23	0,22 MΩ	A9 999 00/220K
R2	18000 Ω	A9 999 00/18K	R24	330 Ω	A9 999 00/330E
R3	1,5 MΩ	A9 999 00/1M5	R25	390 Ω	A9 999 00/390E
R4	39000 Ω	A9 999 00/39K	R26	10 Ω	A9 999 00/10E
R5	33000 Ω	A9 999 00/33K	R27	0,05 MΩ	E 099 BG/AE
R6	22000 Ω	A9 999 00/22K	R28	0,45 MΩ	14+20
R7	2200 Ω	A9 999 00/2K2	R29	15000 Ω	A9 999 00/15K
R8	2800 Ω	A9 999 00/2K2	R30	270 Ω	A9 999 00/270E
R9	82000 Ω	A9 999 00/82K	R31	1000 Ω	A9 999 00/1K
R10	2,2 Ω	A9 999 00/2M2	R32	270 Ω	A9 999 00/270E
R11	0,1 Ω	A9 999 00/100K	R33	0,39 MΩ	A9 999 00/390K
R12	47000 Ω	A9 999 00/47K	R34	18 MΩ	A9 999 00/18M
R13	0,27 Ω	A9 999 00/270K	R35	33 Ω	A9 999 00/33E
R14	0,12 MΩ	A9 999 00/120K	R36	1000 Ω	A9 999 00/1K
R15	15000 Ω	A9 999 00/15K	R37	100 Ω	A9 999 00/100E
R16	47000 Ω	A9 999 00/47K	R38	330 Ω	A9 999 00/330E
R17	68000 Ω	A9 999 00/68K	R60	180 Ω	A9 999 00/180E
R18	10000 Ω	A9 999 00/10K	R61	56 Ω	A9 999 00/56E
R19	1,6 MΩ	E 099 BG/AE	R62	1 MΩ	A9 999 00/1M
R20	0,4 MΩ	14+20	R63	2200 Ω	A9 999 00/2K2
R21	68 Ω	A9 999 00/68E	R64	10000 Ω	A9 999 00/10K
R22	18 MΩ	A9 999 00/18M			

*Handwritten mark*

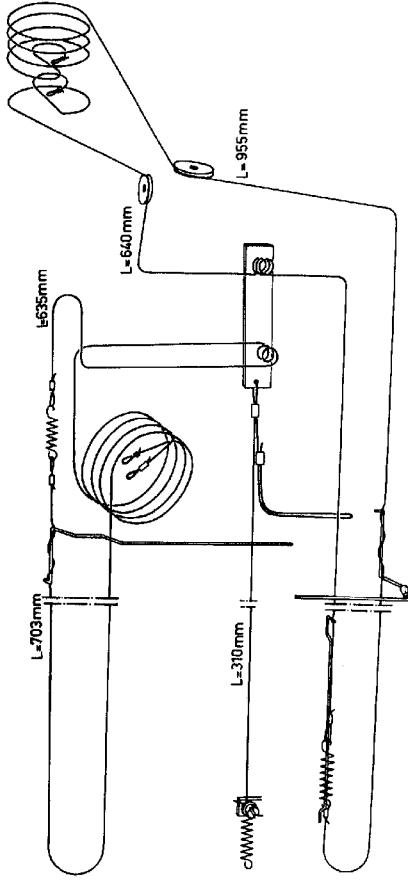

Fig1

S	D.	B	C	A.
L	85.	86.	81, 84, 85, 86, 84, 93, 96, 87, 92, 91, 92, 90, 97, 81, 80, 83	85
R		81.	62, 84.	63, 60.

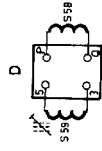
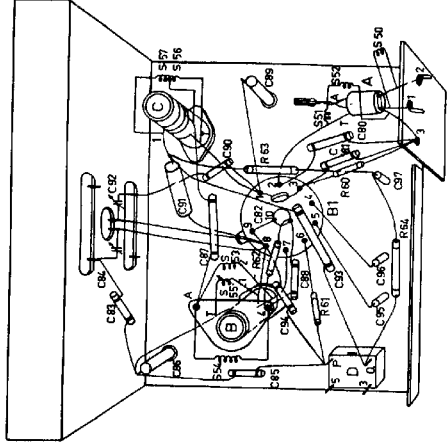

Fig2





S:	27, 24, 26, 25,	H,	E, G,	A, B,	40, A.
C:	42, 46, 48, 47, 49,	49, 39, 37, 34,	33, 30,	15, 54, 31, 14, 52, 32,	16, 11, 26, 50, 5, 2, 1,
R:	17,	27, 28, 25, 20, 19, 24,	22,	30, 28, 23, 18, 35, 21, 31, 27, 15, 16, 14,	6, 36, 29, 5,
				32, 32, 26, 8,	9, 13, 12, 10,
					34, 7, 3, 2, 4, 1, 1a,

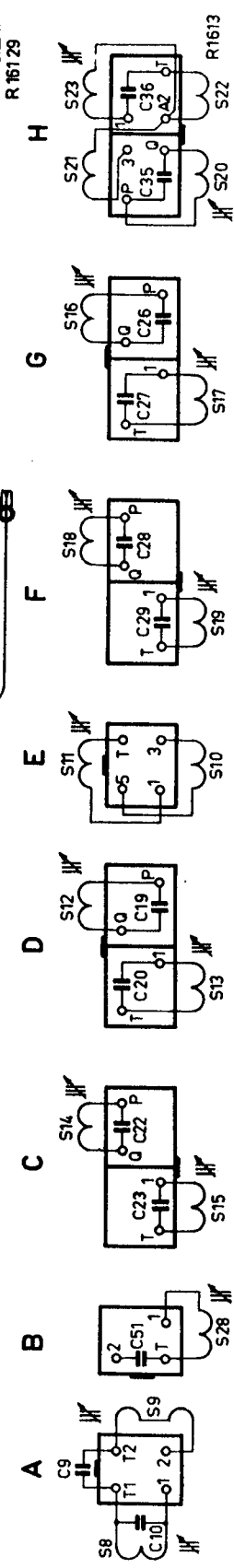
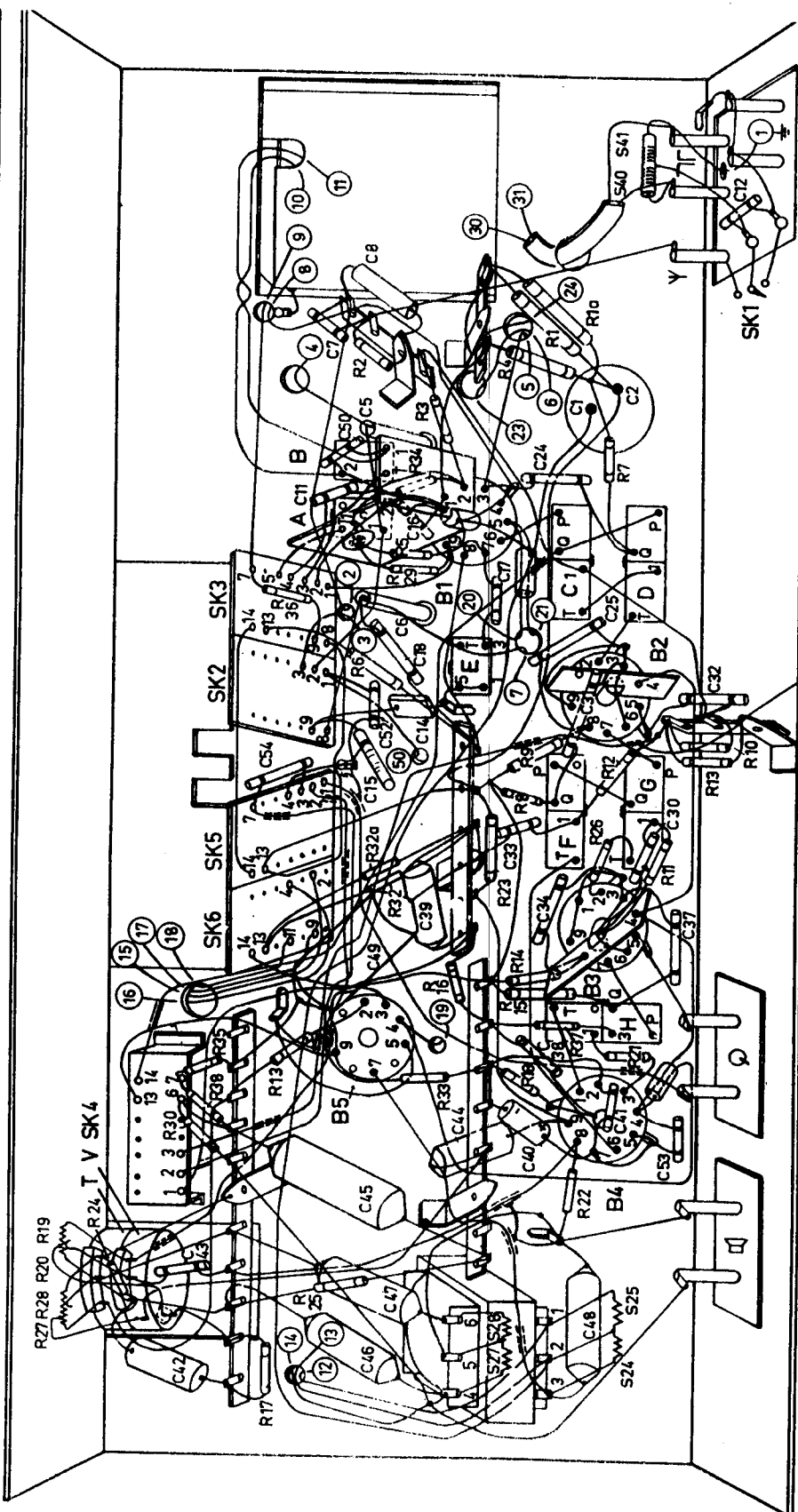

Fig. 4

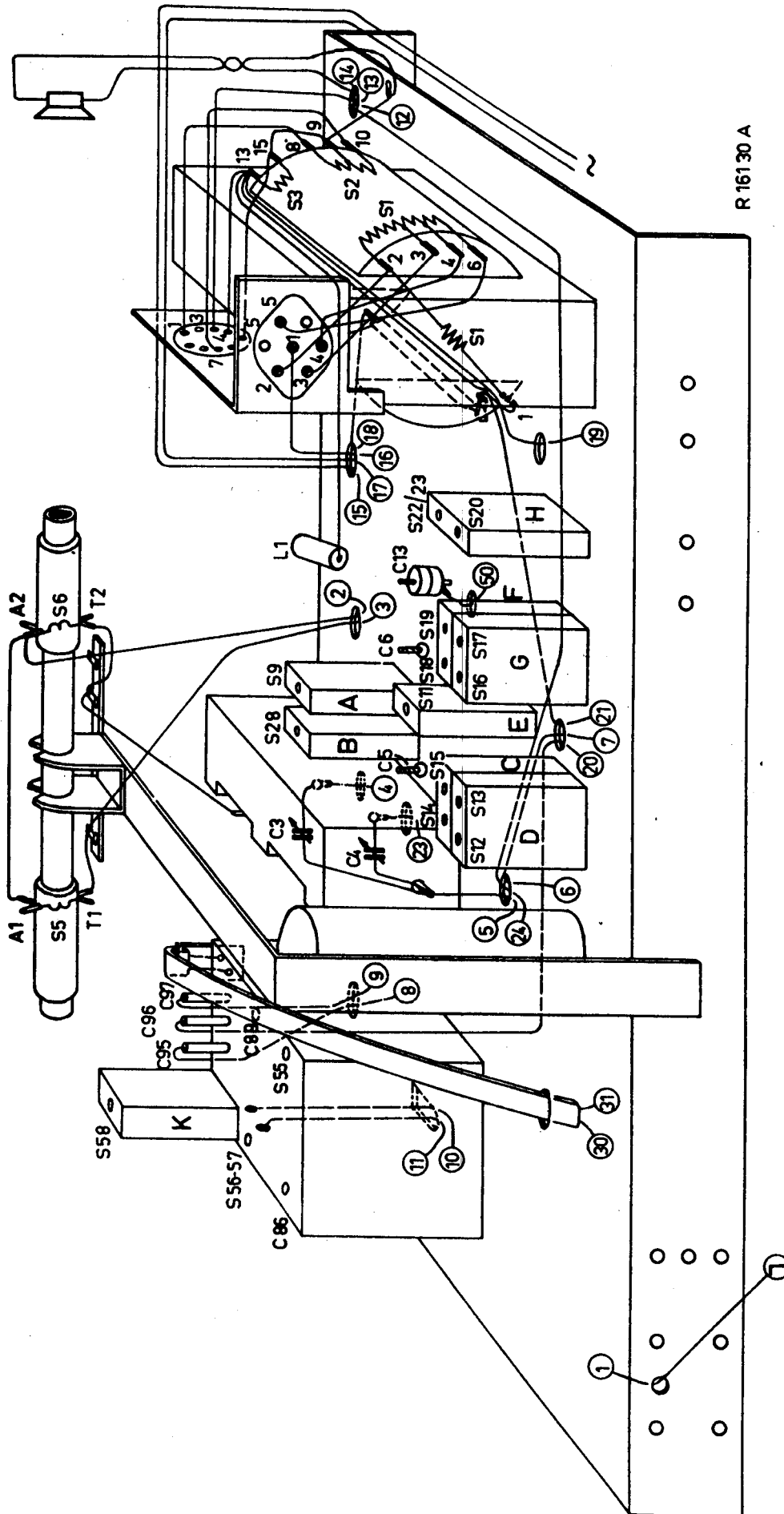

Fig.5